

17305

11718

4 Hours / 100 Marks

Seat No.

--	--	--	--	--	--	--	--

- Instructions :** (1) All Questions are *compulsory*.
(2) Illustrate your answers with neat sketches wherever necessary.
(3) Figures to the right indicate full marks.
(4) Assume suitable data, if necessary.
(5) Mobile Phone, Pager and any other Electronic Communication devices are not permissible in Examination Hall.

- | | Marks |
|---|--------------|
| 1. (A) Draw conventional representation for any six of the following : | 12 |
| (a) Revolved section | |
| (b) Splined shaft | |
| (c) Worm gear | |
| (d) Internal thread | |
| (e) Compression spring with square section | |
| (f) Roller bearing | |
| (g) Globe valve | |
| (h) Knurling | |
| (i) Spring with flat end | |
| (B) Attempt any TWO of the following : | 8 |
| (a) Draw the symbol of the following : | |
| (i) Square butt | |
| (ii) Double J-butt | |
| (iii) Spot weld | |
| (iv) Convex fillet weld | |
| (b) The shaft has size $\phi 50^{0.04}$ and hole size is $\phi 50^{0.00}$. Determine the type of fit between them. | |

(c) State the meaning of the symbol shown in Fig. 1.

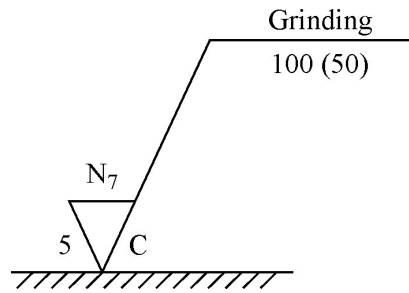

Fig. - 1

2. (A) Fig. 2 shows front view, incomplete top view and auxiliary top view of an object. Redraw the given views and complete the top view. 12

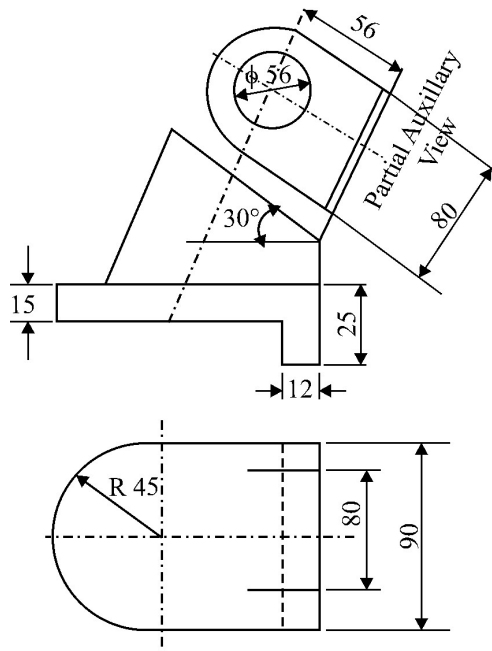

Fig. - 2

(B) Attempt any TWO of the following : 8

(a) Refer Fig. 3. What is the meaning of at 'x' and 'y'

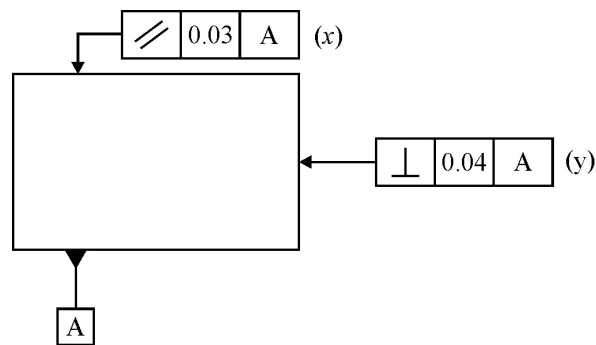

Fig. - 3

- (b) Two mild steel plates of 8 mm thickness are to be welded to have a lap joint by a fillet weld of leg length 8 mm. Represent the weld on drawing with proper symbols.
- (c) Draw the symbols of the following :
- (i) Flatness
 - (ii) Position
 - (iii) Symmetry
 - (iv) Total Run out

3. Attempt any TWO of the following :

20

- (a) A vertical cone of base diameter 100 mm and axis length 90 mm is penetrated by a horizontal cylinder of diameter 50 mm, axis length 120 mm. The axis of the cylinder is parallel to V.P. and is 30 mm above the base cone. The axis of cylinder is 12 mm away from the axis of the cone. Draw the projections of the solids showing curves of intersection.
- (b) A vertical square prism of side 60 mm and height 110 mm is completely penetrated by a horizontal square prism of 45 mm side and 110 mm length. The axis of horizontal prism is 18 mm in front of the axis of vertical prism. All rectangular faces of both the prisms are equally inclined to V.P. Draw the three views showing lines of intersection.
- (c) A vertical cylinder of 60 mm diameter is penetrated by another cylinder of same size. The axis of penetrating cylinder is parallel to both H.P. and V.P. and is 10 mm away from axis of vertical cylinder. Draw the projections of intersection. Assume the length of vertical cylinder as 90 mm and horizontal cylinder with length 100 mm.

P.T.O.

4. Attempt any ONE of the following :

- (a) Fig. 4, shows details of lathe tool post. Draw sectional F.V. and T.V. of the assembly. Prepare bill of material. Indicate type of fit.

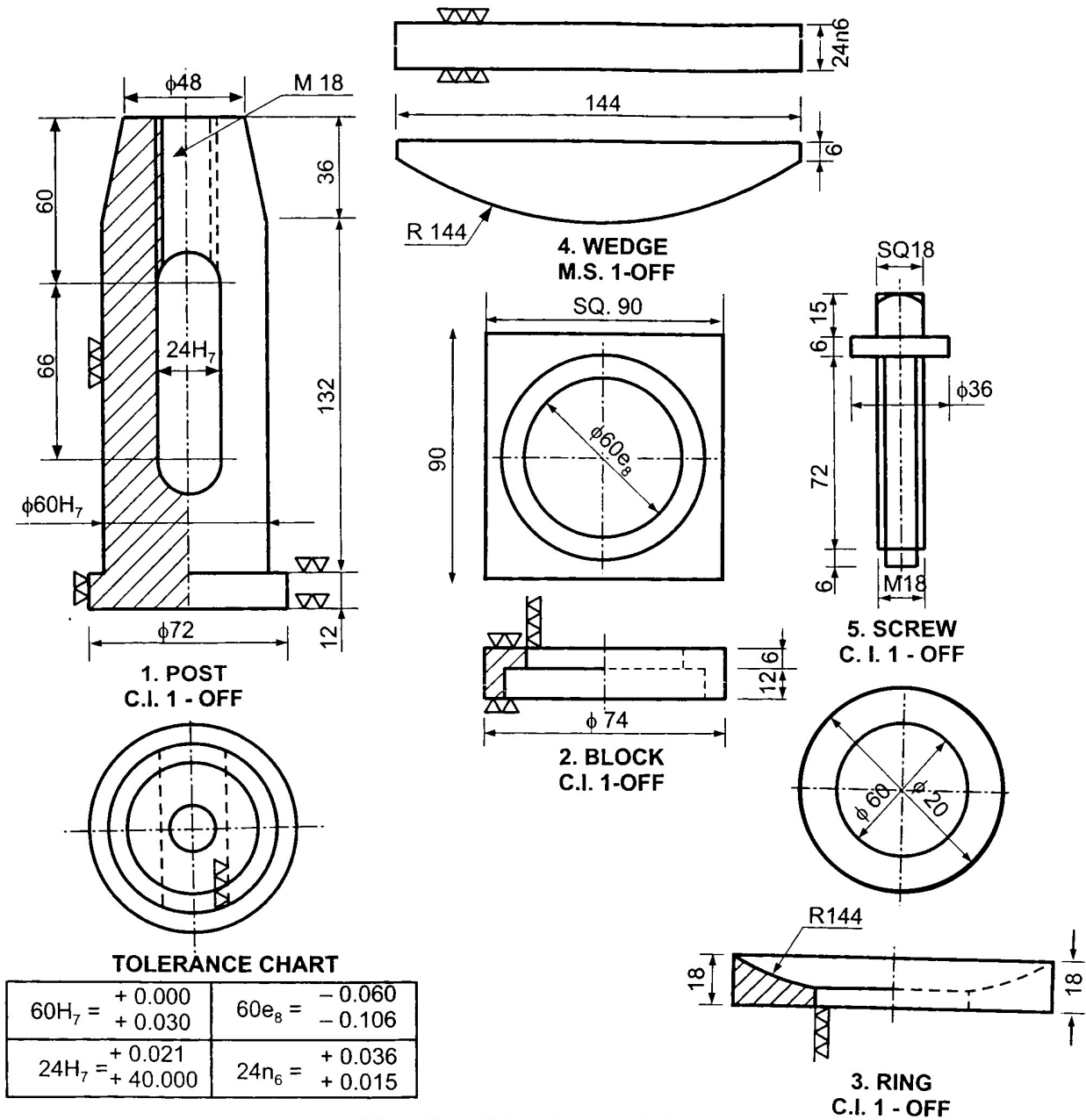

Details of Lathe Tool Post

Fig. - 4

(b) Fig. 5 shows the details of screw jack. Draw sectional F.V. and T.V. of the assembly. Prepare Bill of material.

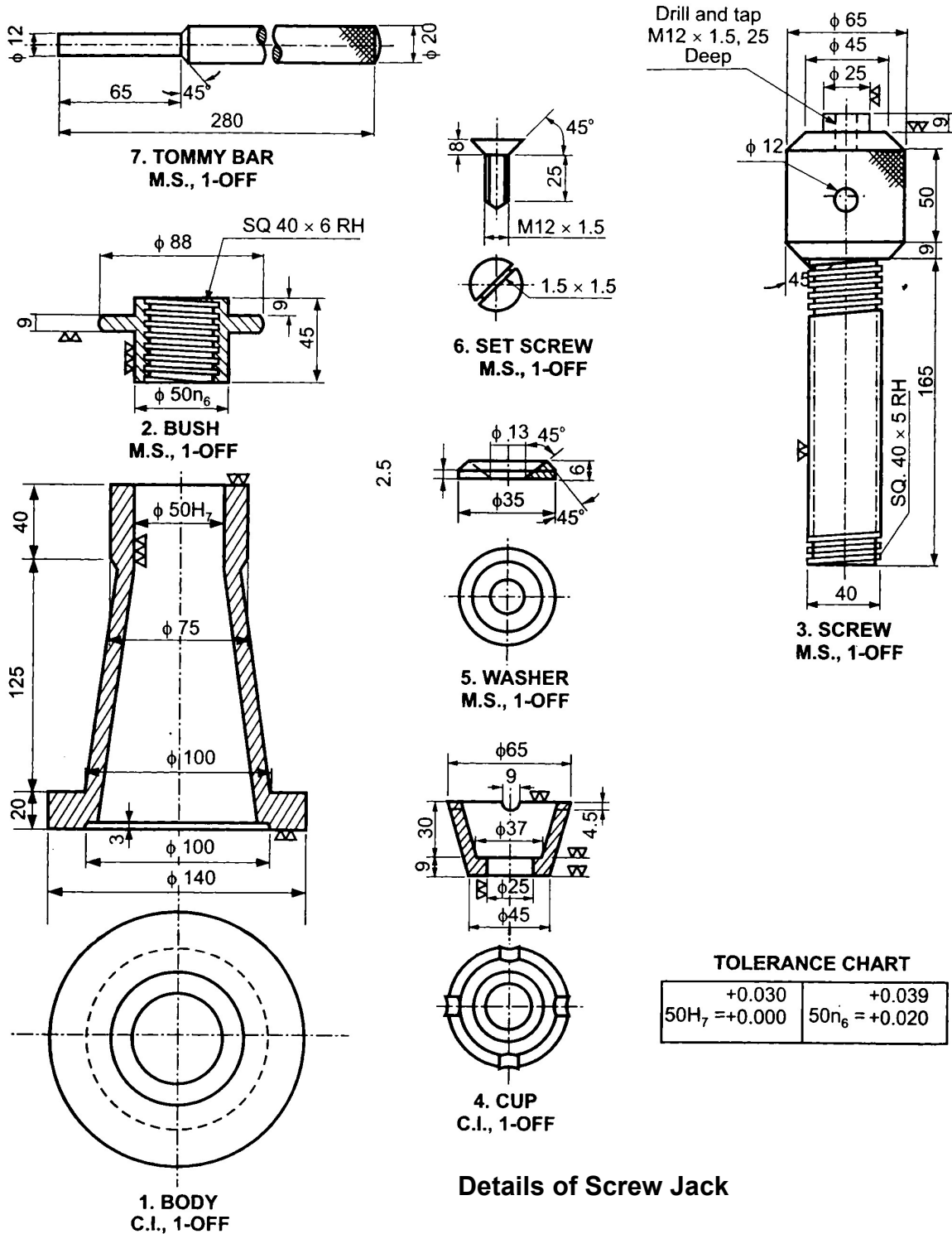

Details of Screw Jack

Fig. - 5

5. Attempt any ONE of the following :

20

(a) Fig. 6 shows the assembly of plummer block. Draw half sectional orthographic views of the following :

- (i) Body – F.V. & T.V. 10
- (ii) Brass – F.V. & T.V. 4
- (iii) Cap – F.V. & T.V. 4
- (iv) Bolt – F.V. & T.V. 2

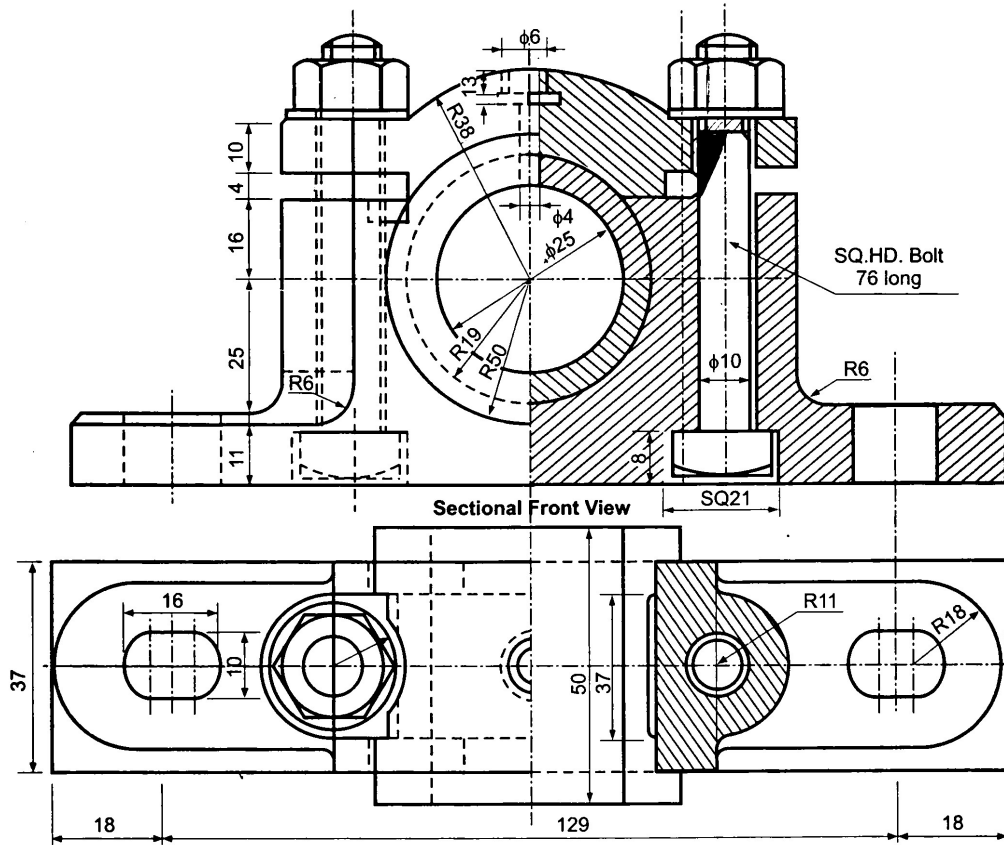

Top View

Bill of Material

Sr. No.	Part Name	Material	Quantity
1	Body	C.I.	1
2	Cap	G.M.	1
3	Brasses	G.M.	1
4	Nut	M.S.	2
5	Nut	M.S.	2
6	Bolt	M.S.	2

Assembly of plummer block

Fig. – 6

(b) Fig.7 shows the assembly of Oldham's coupling. Draw the sectional views of the following :

20

- (i) Flange – F.V. & T.V. 8
- (ii) Central Disc – F.V. & T.V. 8
- (iii) Shaft – F.V. & T.V. 2
- (iv) Taper key 2

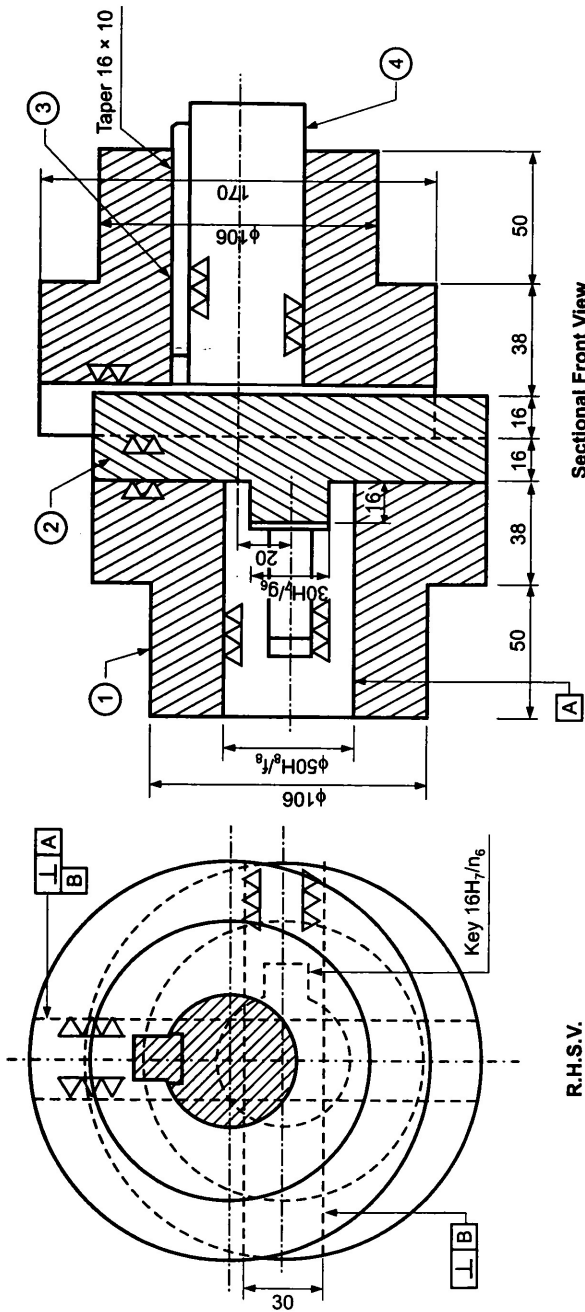

Sectional Front View

R.H.S.V.

Assembly of oldham's coupling

Fig. - 7

PART LIST

Part No.	Part Name	Material	Qty.
1.	FLANGE	C.I.	2
2.	CENTER BLOCK	C.I.	1
3.	KEYS	M.S.	2
4.	SHAFT	M.S.	2

FIT CHART

16H7/n6	TRANSITION FIT
30H7/g6	CLEARANCE FIT
50H8/f6	CLEARANCE FIT

