



MAHARASHTRA STATE BOARD OF TECHNICAL EDUCATION
(Autonomous)
(ISO/IEC -270001 – 2005 certified)

WINTER -2016 EXAMINATION

Subject code:17310

Model Answer

Page No:01/18

Important Instructions to examiners:

- 1) The answer should be examined by keywords and not as word-to-word as given in the model answer scheme.
- 2) The model answer and the answer written by candidate may vary but the examiner may try to assess the understanding level of the candidate.
- 3) The language error such as grammatical, spelling errors should not be given more importance. (Not applicable for subject English and communication skill).
- 4) While assessing figures, examiner may give credit for principal components indicated in the figure. The figure drawn by candidate and model answer may vary. The examiner may give credit for any equivalent figure drawn.
- 5) Credits may be given step wise for numerical problems. In the some cases, the assumed constants values may vary and there may be some difference in the candidates answer and model answer.
- 6) In case of some questions credit may be given by judgment on part of examiner of relevant answer based on candidates understanding

Model Answer with Questions	Marks
Q.1 (A) Attempt any SIX of the following:	12M
a) State any two uses of Plane Surveying.	
Ans: 1) Plane surveying is used for measuring small distance. 2) When area is less than 260 km ² , plane survey is normally done. 3) When desired accuracy is less, plane survey is done.	01 M each
b) State any four classification of surveying based on instrument used.	
Ans: i) Chain survey ii) Plane table survey iii) Theodolite survey, iv) Tachometric survey v) compass survey vi) photographic survey, vii) Aerial survey	½ M each
c) State different tapes used based on material of which they are made.	
Ans: 1) Cloth or Linen tape 2) Metallic Tape 3) Steel Tape 4) Invar Tape 5) Fiber Glass wired Tape	½M each (any four)

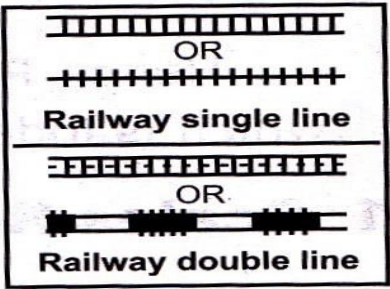
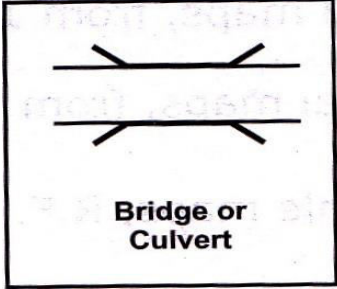
<p>d) Define: i) Open Traverse ii) Closed Traverse.</p>	
<p>Ans: i) Open traverse: When the first and last survey lines does not meets at common point and hence does not form a closed polygon, then it is said to be open traverse. ii) Closed Traverse: When last and first survey stations meet at common point, traverse is called as closed traverse.</p>	<p>01M 01M</p>
<p>e) Define: i) W.C.B. ii) Reduced Bearing.</p>	
<p>Ans: i) Whole circle bearing: The bearing measures only in the clockwise direction from meridian or north direction is known as whole circle bearing. ii) Reduced bearing: The bearing measured with respect to either north or south direction in clockwise or anticlockwise manner is known as reduced or quadrant bearing</p>	<p>01M 01M</p>
<p>f) Enlist the methods of plane tabling.</p>	
<p>Ans : Method of Surveying with the plane table are : 1) Radiation 2) Intersection 3) Traversing 4) Resection</p>	<p>1/2 M each</p>
<p>g) State objectives of levelling.</p>	
<p>Ans : 1) Obtain the level difference between two points. 2) To find the reduced level of points with respect to mean sea level. 3) To obtain the R.L. with respect to arbitrary bench mark. 4) To establish point on a given RL</p>	<p>01 M each (any Two)</p>
<p>h) Define: i) Mean sea level, ii) Station point.</p>	
<p>Ans : i) M.S.L: Mean sea level is the average height of the sea for all stages of tides. It is determined by averaging the hourly tide heights over a long period of 19 years at a place. ii) Station Point : Station point is that point whose elevation is to be determined or station point is a point which is to be established at a given elevation or it is a point where the Staff is held</p>	<p>01M 01M</p>
<p>Q.1 (B) Attempt any TWO of the following:</p>	<p>08</p>
<p>a) Draw conventional symbol for i) Railway line ii) Bridge</p> <div style="display: flex; justify-content: space-around; align-items: center;"> <div data-bbox="153 1720 544 2007" style="border: 1px solid black; padding: 5px;">  <p style="text-align: center;"> Railway single line OR Railway double line </p> </div> <div data-bbox="919 1720 1257 2007" style="border: 1px solid black; padding: 5px;">  <p style="text-align: center;">Bridge or Culvert</p> </div> </div>	

iii) Compound Wall iv) Water pipe-line.

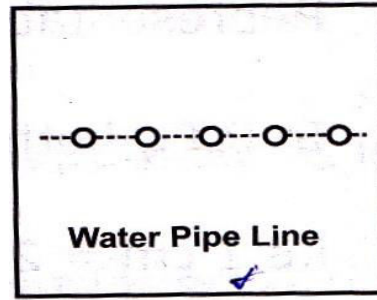
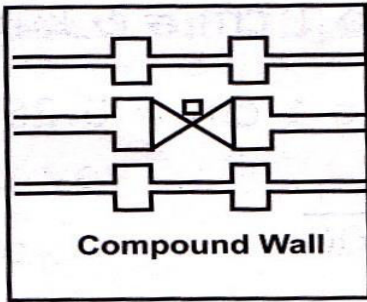

*(one mark each sketch)

*

b) State the classification of surveys based on

- i) The nature of the field of survey.
- ii) The object of survey.

04M

Ans:

i) The nature of the field of survey.

1. Land surveying.
2. Marine surveying or Hydrographic surveying.
3. Astronomical surveying.

*(One mark for each, any two)

ii) The object of survey.

1. Geological surveying.
2. Mine surveying.
3. Archaeological surveying.
4. Military surveying.
5. Engineering surveying.

*(1/2 mark for each, any four)

*

c) State the meaning of local attraction and state its effect on prismatic compass and how it taken care of.

04M

Ans:

Local attraction: It is the deviation or deflection of magnetic needle from its normal position under influence of external magnetic forces is called as local attraction.

01M

Effect on prismatic compass: Due to local attraction, the bearings of the lines observed will be incorrect or having some error.

01M

How is it taken care of:

- 1) The prismatic compass is set up for away from electric cable lines, L.T. line or transmission tower, electric and telephone poles.
- 2) Chains, steel tape, steel arrows, bunch of keys, steel wrist watches, steel buttons etc. are kept away from prismatic compass.
- 3) If local attraction still persists, it is corrected by mathematical calculation.

01 M
each
(any
Two)

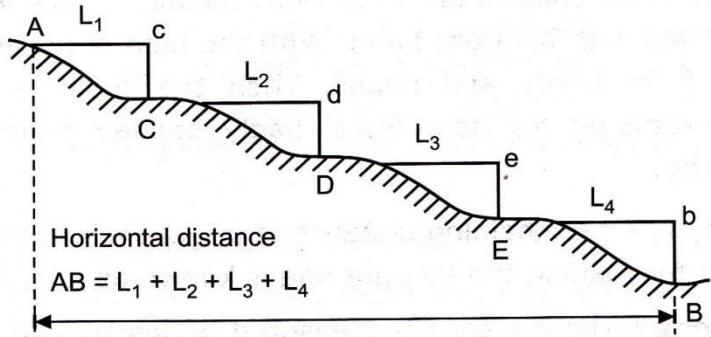
Q. 2 Attempt any Four of the following:	16
a) Explain Direct method of chaining on sloping ground with neat sketch.	04M
<p>Ans:</p> <p>While chaining on sloping ground, the horizontal distances can be computed by direct method i.e. By stepping.</p>  <p style="text-align: center;">Step-by step Chaining by direct method</p> <p>By stepping: It consist in measuring the distance in small horizontal lengths (e.g.L1). Let the horizontal distance between A and B be measured by a chain or tape.</p> <p>A portion of chain say 2m, 4m, 5m, and 10 m is stretched horizontally with one end resting on the ground and other held in line at a convenient height say 1 to 1.5 m. The point vertically below this end is then accurately marked with the help of plumb bob. The next step will then start from this point and method is continued in the correct line with point B. Then length of line $AB=L_1+L_2+L_3+L_4$</p>	<p style="text-align: center;">02M</p> <p style="text-align: center;">02M</p>
b) State the uses of following instruments in survey: i)Cross staff ii) Chain iii) Pegs iv) Arrows	04M
<p>Ans :</p> <p>i) Cross–Staff: To set up perpendicular or right angle to given chain line OR to find foot of perpendicular from given object to a chain line.</p> <p>ii) Chain: Chains are used for measuring distances.</p> <p>iii) Pegs : Pegs are used for marking the positions of station points on survey lines.</p> <p>iv) Arrows : They are used to mark the end of each chain during chaining.</p>	<p>01M</p> <p>01M</p> <p>01M</p> <p>01M</p>
c) Length of a survey line measured with a 20 m chain was found to be 750 m. When the chain was compared with a standard chain, it was found to be 0.20 m too long. Find the length of the line.	04M
<p>Ans :</p> <p>True length= $\frac{L'}{L} \times$ measured Length of line</p> <p>Here L = True length of standard chain = 20m</p> <p>L' = Incorrect length of chain</p> <p>e= 0.20m</p> <p>L'= 20m+0.20m=20.20m</p> <p>Therefore,</p> <p>True length of line = $\frac{20.20}{20} \times 750$</p> <p>True length of line = 757.5 m</p>	<p style="text-align: center;">01M</p> <p style="text-align: center;">01M</p> <p style="text-align: center;">02M</p>

d) Define base line and check line with neat sketch.

04M

Ans :

1) **Base Line** : The longest line running roughly through the middle of the area to be surveyed is known as base line

01M

2) **Check line**: The line joining the apex of a triangle to some fixed point on the opposite side.

01M

OR

A line joining some fixed point on any two sides of a triangle is known as check line.

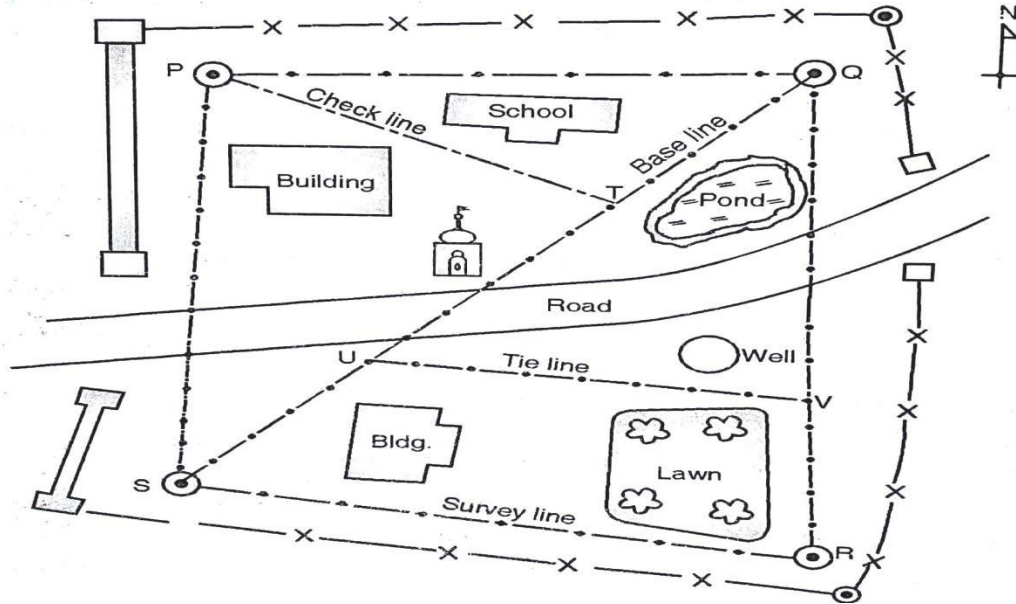

SQ- Base Line, PT- Check Line.

02 M

e) Explain principle of optical square with sketch.

04M

Ans:

Principle of optical square :- The angle between the first incident ray and the last reflected ray is twice the angle between the two mirrors

01M

In the case of optical square the angle between the mirrors is 45° while that between the first incident ray and last reflected ray is 90° .

01M

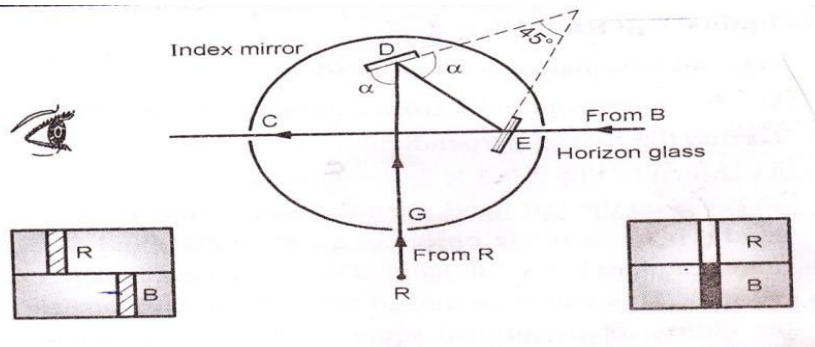

02M

f) Explain reciprocal ranging with neat sketch.

04M

Ans: Reciprocal ranging is done when ends of survey line are not intervisible due to hill intervening or ends of survey line are at far distance apart.

01M

Step wise procedure reciprocal ranging:

1. Let A and B be two survey station. They are not mutually visible due to high ground between them.
2. It is required to measure the distance between A and B. Let two chain-men stands at M_1 and N_1 as shown in fig.
3. The Chain-man at M_1 can see both the ranging rods at N_1 and B. The chain-men at 'N1' can see the ranging at M_1 and A.
4. The two chain-men then direct each other alternately. The chain-man at 'N1' directs the chain-man at M_1 to come in line with AN_1 to occupy position M_2
5. Then the chain-man at M_2 directs the chain-man at N_1 to come in line with $M_2 B$ to occupy position N_2 .
6. By successively directing each other, they finally occupy position 'M' and 'N' on line AB. Now, AMNB are exactly in the same line.
7. Other intermediate points can be fixed by direct ranging and the distance AB can be chained.
8. This method can also be used in ranging a line across a valley.

01M

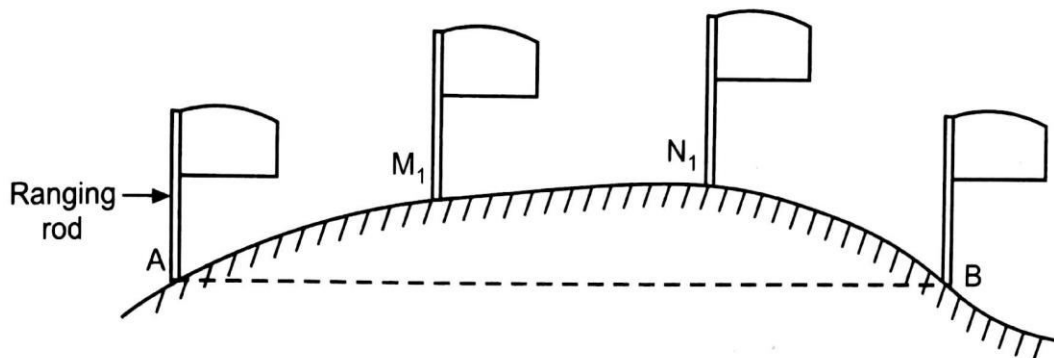

01M

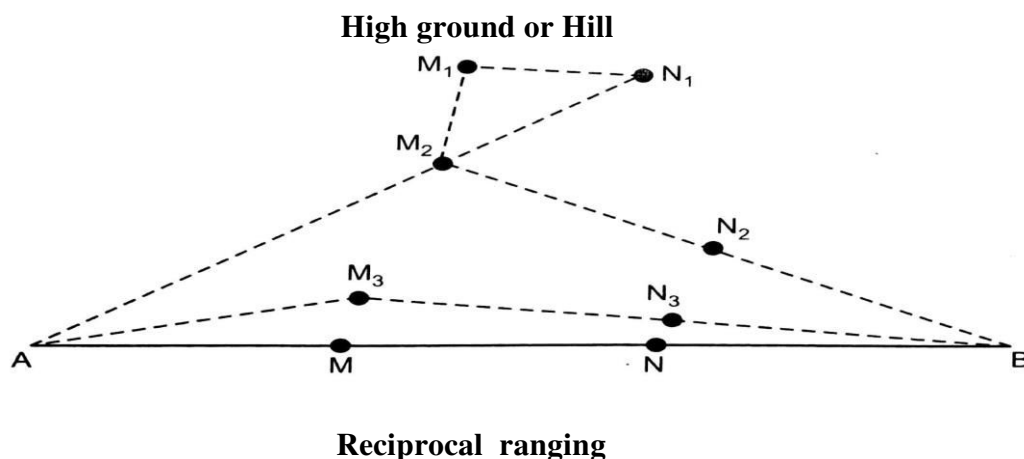

01M

Q. 3 Attempt any FOUR of the following :

16

a) State the procedure to find the foot of the perpendicular on the chain line to take the offset.

04

Ans: By cross staff

1. The cross staff is held vertically on the chain line where the offset is likely to occur. It is turned until one pair of opposite slits is directed to the ranging rod (say B)
2. Though the other pair of slit point P is seen.
3. If it is not seen or bisected, cross staff is moved forward or backward on the chain line until the object P is seen.
4. Then P₁ is the foot of perpendicular on the chain line.
5. Care should be taken to hold the staff vertically and is not twisted round at the time of bisection.

03M

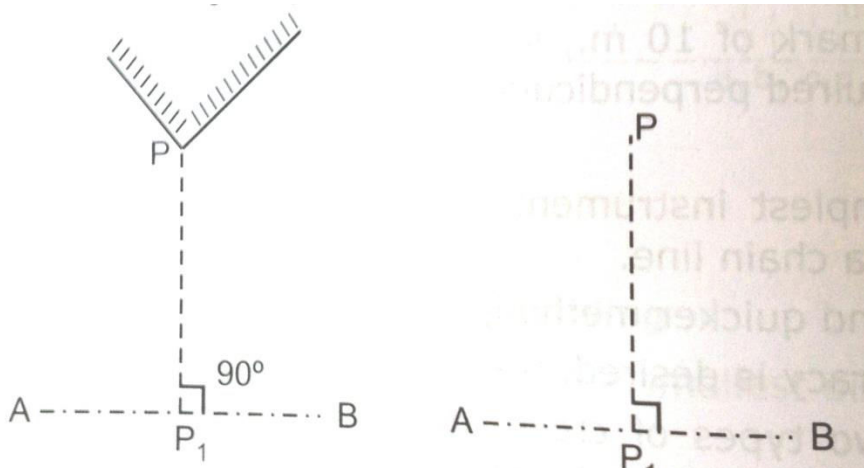

01M

Measurement of perpendicular offset

OR

By Indian optical square:

1. To take on offset to the object P the observer holds the instruments in his hand and stands on the chain line AB.
2. He turns the open face towards the object P, the forward station B is then sighted by looking through the opening which according to as the object P is to his right and walks along the chain line untill object appears exactly in line with the ranging rod at B.
3. The point P₁ vertically under the instruments is required point.

03M

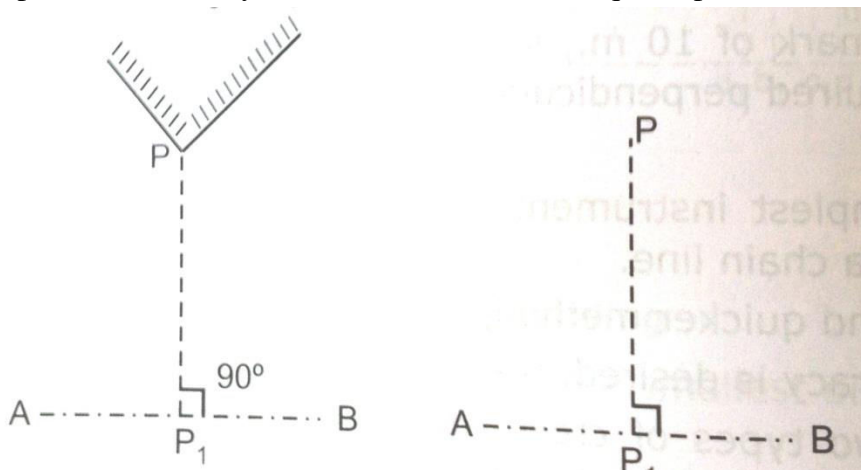

01M

Measurement of perpendicular offset

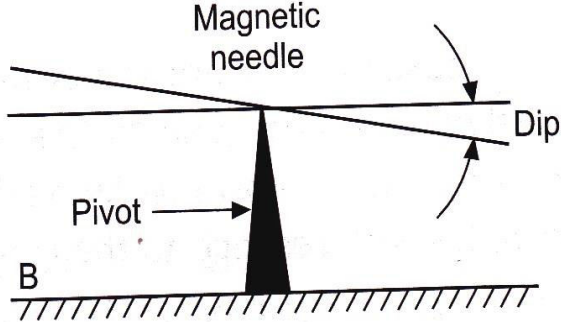
b) State any eight component parts with its functions of prismatic compass.	04
<p>Ans: Component parts of prismatic compass are as follows.</p> <ol style="list-style-type: none"> 1. Break pin - It is used to stop the oscillations of aluminum ring. 2. Lifting pin – It lifts the magnetic needle when sight vane is folded. 3 Sight vane – It is used to sight/bisect object. 4 Graduated ring / Aluminium ring – It is used to observe the angle OR to show the graduations 5. Adjustable Mirror – to bisect the object when it is too high or too low from the line of collimation. 6. Sun Glasses – Used to bisect the luminous object to reduce strain on eyes. 7. Magnetic needle- To direct magnetic north. 8. Pivot- To support the magnetic needle. 9. Reflected prism-observer can see the graduation erect and magnified. 10. Metal cover- It is provided over the glass lid and sighting vane when the compass is not in use to protect the compass from dirt, dust etc. <p style="text-align: center;"><i>*(1/2 mark for each, any eight)</i></p>	<p style="text-align: center;">*</p>
c) Explain dip of magnetic needle with neat sketch.	04
<p>Ans:</p> <ol style="list-style-type: none"> i) The inclination of the magnetic needle with the horizontal is called as magnetic dip of the needle. ii) Ordinary needle if perfectly balanced on pivot, remains in horizontal position. But when the needle is magnetized, it may not always remain in horizontal plane due to the magnetic influence of the earth. iii) In the northern hemisphere the north end of the needle is deflected downwards and in southern hemisphere the south end of the needle points downwards. iv) The dip is not constant but varies in different zones of the earth. It will be zero at the equator and 90° at the poles. v) To keep the needle in horizontal position a brass coil or aluminum strip as sliding weight is attached on the side of the needle which is at higher position. <div style="text-align: center;">  <p style="text-align: center;">Dip of magnetic needle</p> </div>	<p style="text-align: center;">03M</p> <p style="text-align: center;">01M</p>

d) Convert following bearings into R.B :	04
i)129° 30' ii)79°0' iii)295° 30' iv) 212°30'	
<p>i) 129° 30' RB = 180°- WCB RB = 180° -129° 30' RB=S 50°30' E</p> <p>ii) 79°0' RB = WCB RB=N 79°0'E</p> <p>iii) 295° 30' RB = 360°- WCB RB = 360° -295° 30' RB=N64°30'W</p> <p>iv) 212°30' RB = WCB-180° RB = 212°30'-180° RB=S32°30'W</p>	01 mark each
e) Explain four types of meridians.	04
<p>Ans:</p> <ol style="list-style-type: none"> 1. True meridian: -The line which is passing through geographical north or south pole and given point on the surface of earth is called as true meridian. 2. Magnetic meridian:-The direction indicated by a freely suspended and properly balanced magnetic needle unaffected by local attractive forces is called as magnetic meridian. 3. Arbitrary meridian:- For small project any convenient direction may be taken as arbitrary meridian. 4. Grid meridian:- Sometimes, for preparing a map some state agencies assume several lines parallel to true meridian for a particular zone. These lines are termed as grid lines and the centre line as the grid meridian. 	01M 01M 01M 01M
f) State different methods of plotting compass traverse.	04
<p>Ans: Methods of plotting compass traverse are:</p> <ol style="list-style-type: none"> 1. By parallel meridian through each station. 2. By included angle. 3. By paper protractor. 4. By rectangular co-ordinates. 5. Plotting by tangents. 6. Plotting by chords. 	01 mark each (any Four)

Q.4 Attempt any four the following :	16
a) Convert following reduced Bearings into W.C.B.	
i) N45°00'W ii)S20° 00'E iii) S 53°00'W iv)N 38°00' E	04M
<p>i) N45°00'W WCB = 360° - RB WCB = 360° - 45°00' WCB = 315°00'</p> <p>ii)S20° E WCB = 180° - RB WCB = 180° - 20°00' WCB = 160°00'</p> <p>iii) S 53°W WCB = 180°+ RB WCB = 180°+53°00' WCB = 233°00'</p> <p>iv) N 38° E WCB = RB WCB = 38°00'</p>	01 mark each
b) Define orientation and principle of plane tabling.	04
<p>Ans:</p> <p>Orientation: The orientation of plane table means keeping the plane table at all stations parallel to the position it occupied at first station.</p> <p>Principles of plane table survey:</p> <ol style="list-style-type: none"> 1. The rays drawn from different points should pass through a single point i.e. position of station point. 2. The position of table should be same as that of previous station i.e. orientation should be done at each changed station. 	02M 02M
c) Explain the radiation method of plane table survey with neat sketch.	04
<p>Ans: This method is used when all the points to be plotted are visible from single instrument station. Steps are:</p> <ol style="list-style-type: none"> 1. Select a suitable point P on the ground such that all the details are visible from it. 2. Center and level the plane table over P. 3. Mark the direction of the North on the sheet by using compass. 4. Locate instrument station(P) on the sheet (p) by using plumbing fork, such that p on sheet is exactly over P on ground. 5. Centering the alidade on point p, sight various details step by step and draw a ray from each detail along the fiducial edge of the alidade. 6. Let the details be named as A, B, C, D, E etc. 7. Now measure the distances of each point from P i.e. PA, PB, PC, PD, PE and plot them to scale on the sheet as pa, pb, pc, pd, pe respectively. Join a, b, c, d, and e to give the outline. 	02M

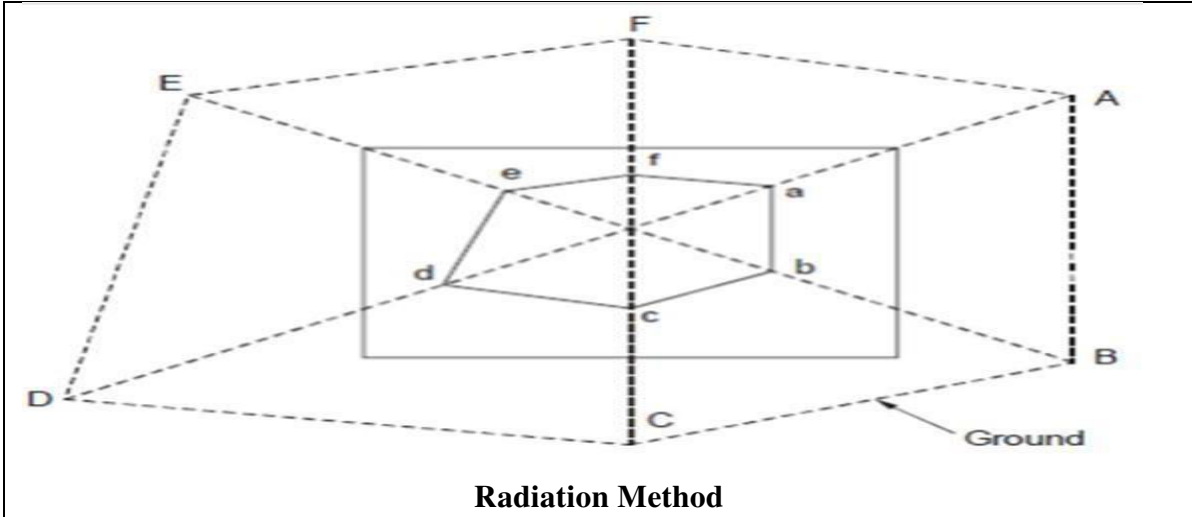

Radiation Method

02M

d) State merits and demerits of plane table surveying.

04

Ans:

Merits :-

1. It is the most rapid method of surveying.
2. There is no need for a field book as plotting is done along with the field work. So, the problem of mistakes in booking field notes does not arise.
3. Plotted work can be compared with actual object regardless of whether or not they are properly represented.
4. There is no possibility of overlooking any important object.
5. There is no possibility of overlooking any measurement as plotting is done in the field.
6. Irregular objects may be represented accurately.
7. It is suitable in magnetic areas.
8. The map can be prepared easily, and does not require any great skill.
9. Errors in measurement and plotting can be detected by check lines.
10. Inaccessible points can be easily located by intersection.

**(Any four 1/2 mark each)*

Demerits :-

1. The plane table survey is not possible in unfavorable climates such as rain, fog etc.
2. This method of survey is not very accurate and thus unsuitable for large scale or precise work.
3. As no field book is maintained, plotting at different scale require full exercise.
4. The method requires large amount of time to be spent in the field.
5. Quality of the final map depends largely on the drafting capability of the surveyor.
6. This method is effective in relatively open country where stations can be sighted easily.
- 7 Instrument is heavy and cumbersome to carry
- 8 There are number of accessories which may be lost.

**(Any four 1/2 mark each)*

*

*

e) Explain errors occurred due to manipulation and sighting in plane tabling.	04
Ans: i) The board not being horizontal- This error affects chiefly the measurement of vertical angles. ii) The table not being accurately centered. The plotted position of the occupied station not being exactly over the station on the ground. iii) The table not being correctly oriented. To prevent this error, the orientation of the table should be checked at as many stations as possible by back sighting or by magnetic meridian. iv) The table being displaced from its initial position. There is likely to be slight rotation or other displacement of the table. Frequent check-sight should be taken to detect and correct any displacement. v) The defective sighting- The object not being correctly sighted.	01M each (any four)
f) Define: i) Level Line, ii) Horizontal Line, iii) Vertical Line iv) Bench Mark.	04
Ans: j) Level Line: It is line lying in a level surface; it is therefore, normal to the plumb line at all points. ii) Horizontal Line: It is a straight line tangential to the level line at a point. It is also perpendicular to plumb line. iii) Vertical Line: The direction indicated by a plumb line (the direction of gravity) is known as vertical line. This is perpendicular to the horizontal line. iv) Bench Mark: These are fixed points or marks of known RL determined with reference to the datum line. They serve as reference points for finding RL of new points.	01M 01M 01M 01M
Q.5 Attempt any FOUR of the following:	16
a) Define the following : i)Height of instrument ii) Back sight iii) Fore Sight iv)Axis of bubble tube	04M
Ans: i) Height of instrument : The elevation (R.L.) of the plane of collimation with respect to the datum when the instrument is correctly leveled is known as height of instrument ii) Back sight: The first staff reading taken on a point of known elevation (i.e. B.M. or C.P.) after the level is set up and leveled is known as back sight. iii) Fore sight: The last staff reading taken on a point denoting the shifting of the instrument whose elevation is to be determined as on change point or end point. iv) Axis of bubble tube: An imaginary line tangential to longitudinal curve of the bubble tube at its middle point is known as axis of bubble tube.	01M 01M 01M 01M

b) Differentiate between H.I. method and rise and fall method			04
Ans:			*
Sr.No	H.I. Method	Rise and Fall Method	
1	It is more rapid and less tedious	It is slow and more tedious.	
2	It is simple as it involves less calculations.	It is laborious as it involves more calculations.	
3	In this method there is no check on calculations of R.L. of intermediate sight and mistakes made remain unchecked	In this method there is complete check on all calculation work.	
4	In this method the error in calculating the R,L, of I.S. is not carried forward as the R,L, are calculated from the respective plane of collimation	In this method the mistake made in calculating the R.L. of any point will be carried forward.	
5	It is usually used in profile leveling calculation.	It is used in precise leveling work, check leveling calculations.	
6	Arithmetical check $\Sigma B.S. - \Sigma F.S = \text{Last RL} - \text{First RL}$	Arithmetical check $\Sigma B.S. - \Sigma F.S = \Sigma \text{Rise} - \Sigma \text{fall} = \text{Last RL} - \text{First RL}$	
<i>*(Any four points 1 mark each)</i>			
c) State different types of leveling. Explain any one in brief.			04
Ans:			01/2M each (any four)
<p>Types of Levelling</p> <ol style="list-style-type: none"> 1. Simple Levelling. 2. Differential Levelling. 3. Fly Levelling. 4. Longitudinal or profile leveling. 5. Cross-Section Levelling. 6. Check Levelling. <p>1. Simple Levelling-</p> <p>When the difference of level between two points is determined by setting the leveling instrument midway between the points, the process is called simple leveling.</p> <p>Suppose A and B are two points whose difference of level is to be determined. The level is set up at O, exactly midway between A and B. After proper temporary adjustment, the staff readings on A and B are taken. The difference of these readings gives the difference of level between A and B.</p>			
			01M

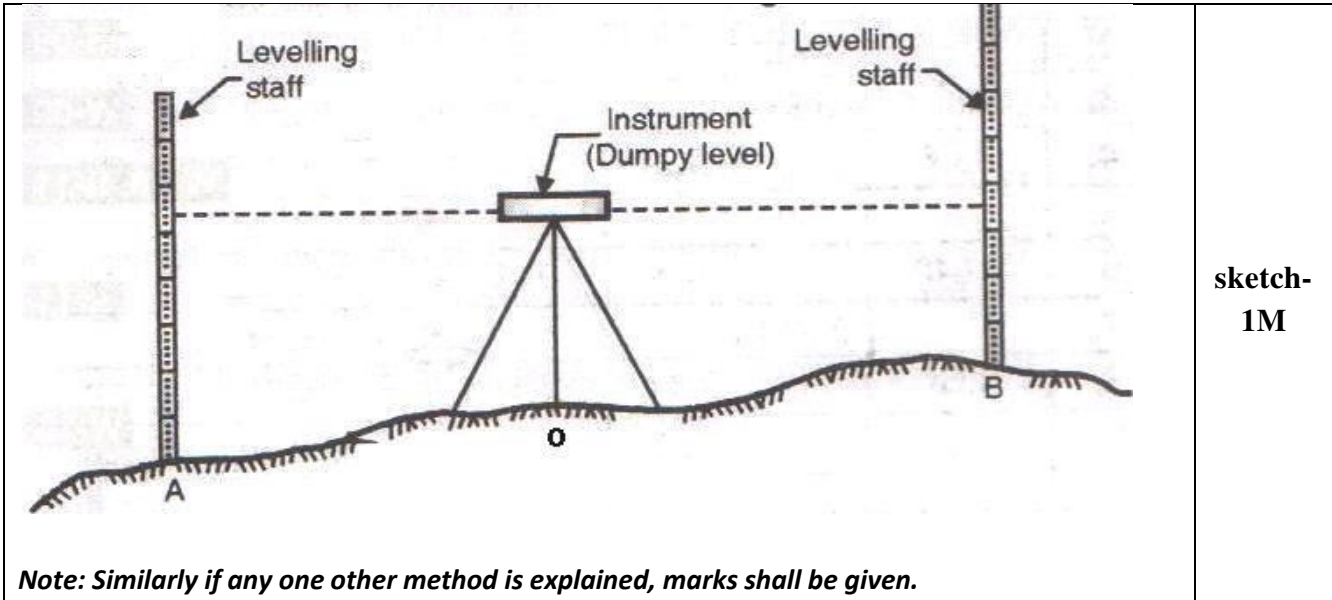

sketch-
1M

Note: Similarly if any one other method is explained, marks shall be given.

d) State the important point to be remembered while doing profile leveling.

04

Ans:

1. The chainage of staff stations are continuous from beginning to the end of the section line.
2. Readings of B.S. and F.S. should be taken very accurately with the bubble exactly in the center of its run.
3. To eliminate the instrumental error, the back sight and fore sight distance should be approximately equal.
4. The features such as nalla, river, road, canal etc. crossed by the line should be fully located by taking bearing of their centre lines, their width or by offset.
- 5) All the temporary adjustments at all instrument position shall carefully be done.

*

**(Any four 1 mark each)*

e) Explain temporary adjustments of a Dumpy Level.

04

Ans:

1. Setting up the level.

- a. The level fixed on tripod.
- b. The legs of tripod stand are well spread so that the level will remain stable on tripod.
- c. Bring all the three foot screws in the centre of their run so that they can be turned clockwise or anticlockwise as required, for levelling purpose
- d. Adjust the height of the instrument so that the observer can comfortably see through the telescope and note the readings.
- e. Fix two legs of tripod and adjust third leg in such a way that the levelling head will become as horizontal as possible by eye judgment.

01M

2. Levelling up the level.

- a. The base of the tripod is already leveled with the help of cross bubble.
- b. To make accurate adjustment of the level, the longitudinal level is adjusted in the centre of its run, with the help of three foot screws.
- c. Make the bubble parallel to the any selected pair of foot screws. Now; turn both the foot screws either inward or outward with the help of foot screws till the bubble appears in the center.

01M

d. Turn the telescope through 90° as shown in fig. below and now with the help of third screw bring the bubble of levelling tube in the center.

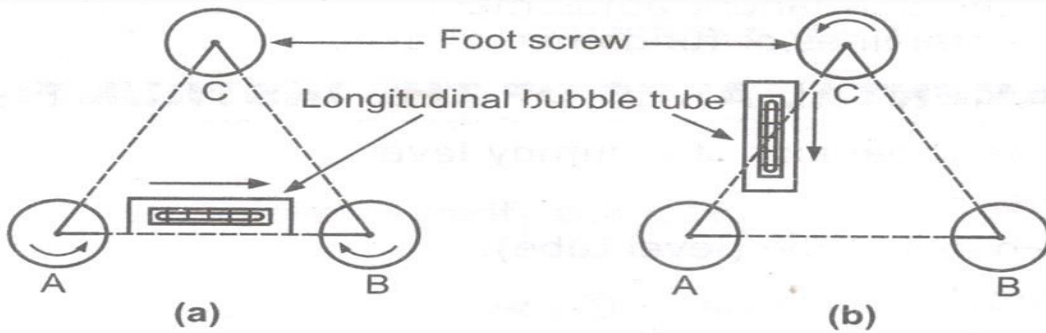

3. Focusing the Eye piece.

- Hold a sheet of white paper in front of the objective glass 4 to 6 cm away from objective glass and see through the eye piece.
- Turn the eye piece inwards or outwards in the socket so that the cross hair on the diaphragm appears sharp and clear.

01M

4. Focusing the Object glass.

- Direct the telescope towards any object, say a levelling staff in the field which is kept at a distance. See through eyepiece whether the staff is visible, distinct or not.
- If not, then turn the focusing screw till the image is distinct and clear. The cross hair on the diaphragm should also be seen clearly.

01M

f) Draw a neat sketch of dumpy level and name all parts.

04

Ans:

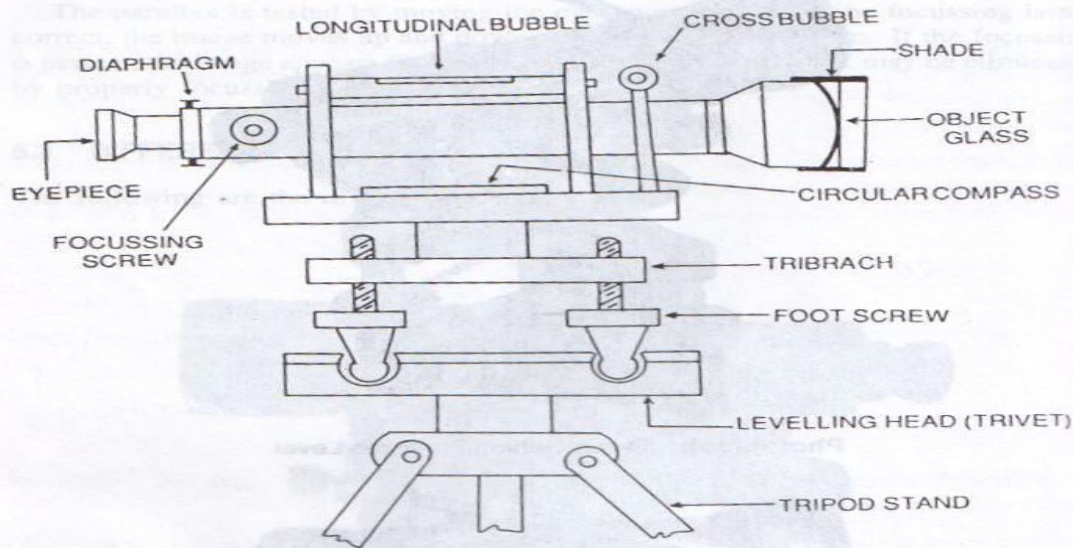

*

*(Sketch 03 marks , labeling 01 marks)

Q.6 Attempt any TWO of the following

16

a) Plot the following cross staff survey of field and calculate its area in m^2 as shown in fig.No.1.

08

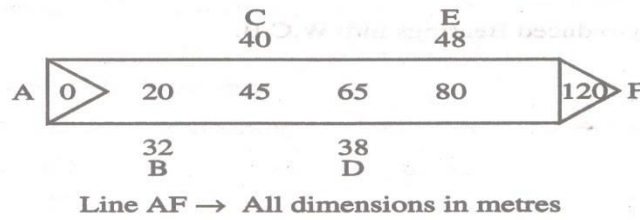

Ans:

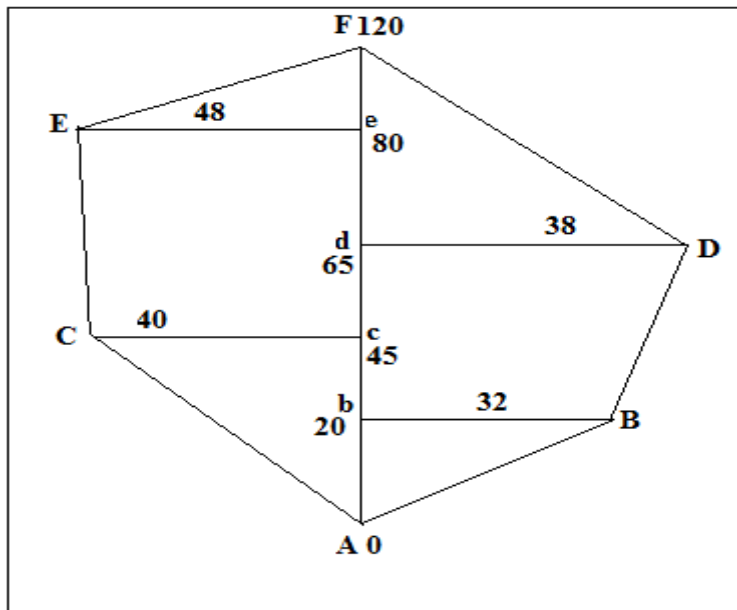

*

Sr. No.	Fig No	Chainage (m)	Base (m)	Offset(m)	Mean offset(m)	Area (m^2) (Base X Mean offset)
1	Δ Acc	0 & 45	45	0 & 40	20	900
2	∇ CceE	45 & 80	35	40 & 48	44	1540
3	Δ EeF	80 & 120	40	48 & 00	24	960
4	Δ FdD	65 & 120	55	38 & 00	19	1045
5	∇ DdbB	20 & 65	45	32 & 38	35	1575
6	Δ BbA	00 & 20	20	00 & 32	16	320
Total Area						6340 m^2

**(fig-01 Mark, each area calculation-01 Mark each, Total area-01 Mark)*

<p>b) Calculate the included angle for a closed traverse survey and apply usual check. Find Corrected FB and BB</p> <table border="1"> <thead> <tr> <th>Line</th> <th>FB</th> <th>BB</th> </tr> </thead> <tbody> <tr> <td>AB</td> <td>46°30'</td> <td>226°30'</td> </tr> <tr> <td>BC</td> <td>118°0'</td> <td>297°30'</td> </tr> <tr> <td>CD</td> <td>168°30'</td> <td>349°30'</td> </tr> <tr> <td>DA</td> <td>292°00'</td> <td>110°30'</td> </tr> </tbody> </table>	Line	FB	BB	AB	46°30'	226°30'	BC	118°0'	297°30'	CD	168°30'	349°30'	DA	292°00'	110°30'	08
Line	FB	BB														
AB	46°30'	226°30'														
BC	118°0'	297°30'														
CD	168°30'	349°30'														
DA	292°00'	110°30'														
<p>Ans: Sample Calculation Step -1 Observed included angle $\angle A = \text{B.B of line DA} - \text{F.B of Line AB}$ $= 110^\circ 30' - 46^\circ 30'$ $\angle A = 64^\circ 0'$ $\angle B = \text{B.B. of Line AB} - \text{F.B of line BC}$ $= 226^\circ 30' - 118^\circ 0'$ $\angle B = 108^\circ 30'$ $\angle C = \text{B.B of line BC} - \text{F. B of Line CD}$ $= 297^\circ 30' - 168^\circ 30'$ $\angle C = 129^\circ 0'$ $\angle D = \text{B.B of line CD} - \text{F. B of Line DA}$ $= 349^\circ 30' - 292^\circ 0'$ $\angle D = 57^\circ 30'$</p> <p>Step – 2 Sum of all observed included angle $= \angle A + \angle B + \angle C + \angle D$ $= 64^\circ 0' + 108^\circ 30' + 129^\circ 0' + 57^\circ 30'$ $= 359^\circ 0'$</p> <p>Step – 3 for closed traverse of included angle $= (2n-4) \times 90$ $= (2 \times 4 - 4) \times 90 = 360^\circ$ Error in sum of = observed including angle - 360° $= 359^\circ 0' - 360^\circ 0'$ $= -1^\circ$</p> <p>Error is negative and correction is positive</p> <p>Step – 4 Correction in each angle $= 1^\circ / 4 = 0^\circ 15'$</p> <p>Step – 5 Corrected included angle. $= \text{observed included angle} + \text{correction}$ $\angle A = 64^\circ + 0^\circ 15' = 64^\circ 15'$ $\angle B = 108^\circ 30' + 0^\circ 15' = 108^\circ 45'$ $\angle C = 129^\circ + 0^\circ 15' = 129^\circ 15'$ $\angle D = 57^\circ 30' + 0^\circ 15' = 57^\circ 45'$</p> <p>Step – 6 Apply usual check corrected of all included angle = (2n-4) x 90 $\angle A + \angle B + \angle C + \angle D = (2 \times 4 - 4) \times 90$ $64^\circ 15' + 108^\circ 45' + 129^\circ 15' + 57^\circ 45' = 360^\circ$ $360^\circ = 360^\circ$ Hence Ok.</p> <p style="text-align: center;">*(Note: If the students attempt upto step-3, full marks may be given)</p>	<p>02M</p> <p>01M</p> <p>01M</p> <p>01M</p> <p>01M</p> <p>02M</p>															

c) The following are the consecutive readings on 4 m leveling staff on a continuously sloping ground of 30m.
0.880,1.600,1.970,2.550,2.990,3.485,1.250,1.980,2.465,3.740,0.920,1.145,1.850,2.740.
 the R.L. of first point is 200.00m. Rule out a page of level field book and enter above readings. Calculate the reduced levels of all the points by rise and fall method.

08

Ans:

Staff station chainage	B.S.	I.S.	F.S.	Rise(+)	Fall (-)	R.L.	Remark
A 0	0.880					200.00	B.M.
30		1.600			0.720	199.280	
60		1.970			0.370	198.910	
90		2.550			0.580	198.330	
120		2.990			0.440	197.890	
150	1.250		3.485		0.495	197.395	C.P.1
180		1.980			0.730	196.665	
210		2.465			0.485	196.180	
240	0.920		3.740		1.275	194.905	C.P.2
270		1.145			0.225	194.680	
300		1.850			0.705	193.975	
B 330			2.740		0.890	193.085	
	$\Sigma=3.050$		$\Sigma=9.965$	$\Sigma=0$	$\Sigma=6.915$		

Arithmetic check

$$|\Sigma \text{ B.S.} - \Sigma \text{ F.S.}| = |\Sigma \text{ Rise} - \Sigma \text{ Fall}| = |\text{Last R.L.} - \text{First R.L.}|$$

$$|3.050 - 9.965| = |0 - 6.915| = |193.085 - 200|$$

$$|-6.915| = |-6.915| = |-6.915|$$

Note: *Draw the table = 01 Mark, Entry of Correct readings = 02 Marks, Each correct R.L. calculations = 1/4 Marks and exact check = 02 Marks.